

MdG= da 580 a 6000 Nm

Esecuzione Cod OMS2

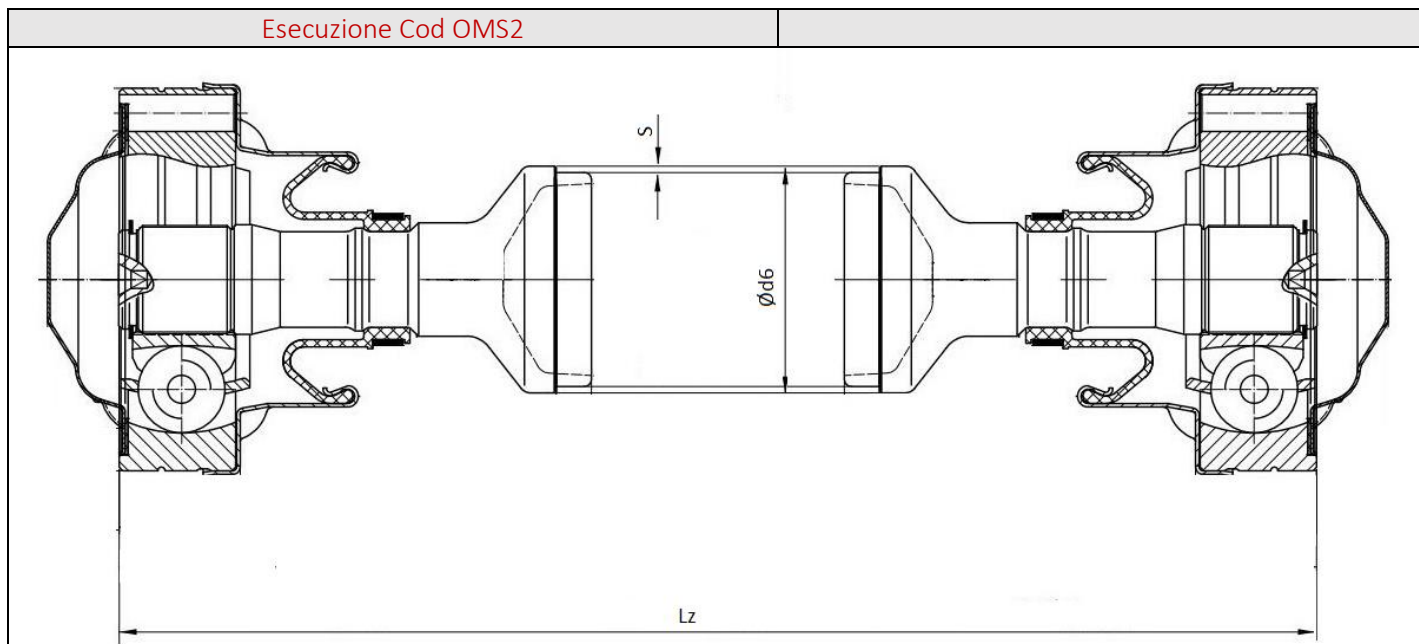

Dimensione	MdG	$\beta$ max.	$\varnothing d6+S$
05	580	15°	40x2
13	1300	15°	50.8x2.41
15	2500	15°	60x3
21	3500	15°	76.2x2.41
32	6000	15°	90x3